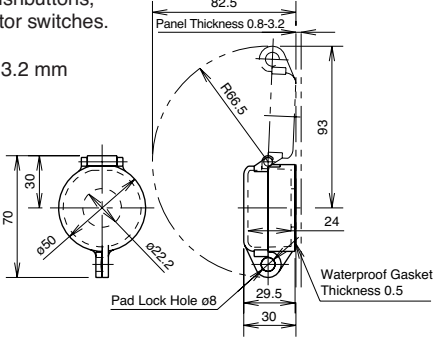
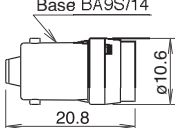
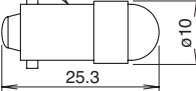
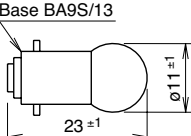
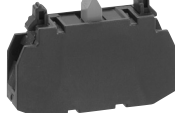
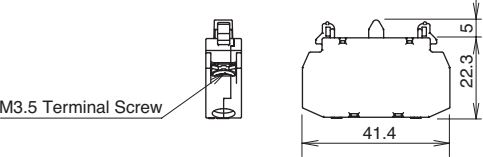
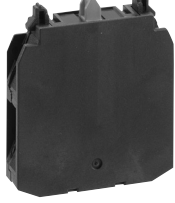
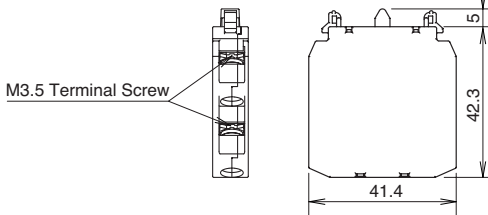

Name & Shape	Type No.	Description & Dimensions (mm)		Package Quantity
	HW9Z-KL1	Plastic hinged cover to protect pushbuttons, illuminated pushbuttons, or selector switches. Degree of protection: IP65. Applicable panel thickness: 0.8 to 3.2 mm 		1
LED Lamp 	LSED-6②	6V AC/DC	Specify a color code in place of ② in the Type No. A (amber), G (green), PW (pure white), R (red), S (blue), Y (yellow) Applicable units: • LED illuminated pilot lights • LED illuminated pushbuttons For the rated current, see page 4. Note: Yellow LED lamps are used for white illumination of pilot lights and illuminated pushbuttons.	1
	LSED-1②	12V AC/DC		
	LSED-2②	24V AC/DC		
LED Lamp 	LSED-H②	110V AC/DC		
Incandescent Lamp 	LS-T6P	6.3V, 1W	One pack contains 100 incandescent lamps.	100
	LS-T8P	18V, 1W		
	LS-T3P	30V, 1W		
Single Contact Block 	YW-E10P	Contact: 1NO		10
	YW-E01P	Contact: 1NC		
Double Contact Block 	YW-EW20P	Contact: 2NO		10
	YW-EW11P	Contact: 1NO-1NC		
	YW-EW01P	Contact: 2NC		