

Motor starters

# EasyPact TVS

Designed for the essential



**Thiết Bị Điện Công Nghiệp & Dân Dụng**

32 Đường 35, kp.2, p.Linh Đông, q.Thủ Đức, tp.HCM

Tel: 08 3720 2968 - Fax: 08 3720 2974 - Email: sales@thegioidien.com

**Schneider**  
Electric

# EasyPact TVS: control & protection,



Leader in the motor starter market for more than 80 years, Schneider Electric has designed EasyPact TVS range to provide you with the competitive solutions you were expecting.

**EasyPact TVS starters range is the perfect fit between quality, features and price.**



## A cost-effective offer

- > The best price for the performance and quality level you need.
- > A maximum of solutions with an optimal number of products.
- > Designed to perform the essential starter's functions: control and overload protection.

## Simple and intuitive

- > Easy to install.
- > Covering 80 % of applications.
- > With the key accessories to easily build lots of Do-It-Yourself solutions.
- > With an intuitive commercial references system: easy to order, easy to understand and easy to remember.

## Guaranteed availability

- > Available in distribution.
- > EasyPact TVS fully benefits from Schneider Electric world wide policies: in terms of standards of production, distribution, quality, availability, services and after-sales support.

in a simple way

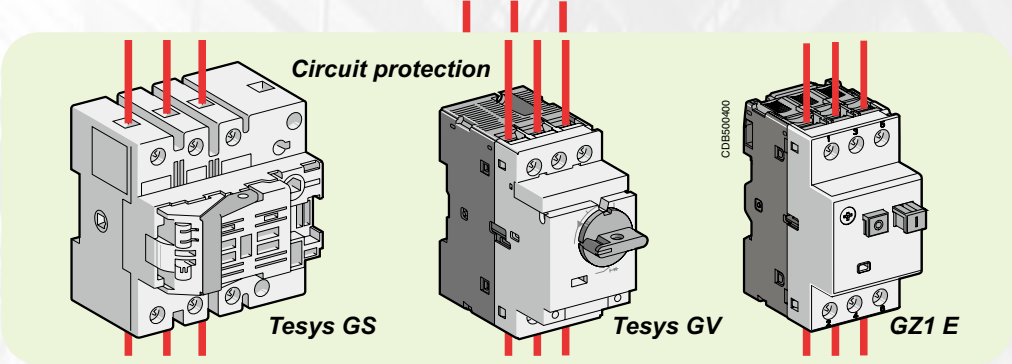

**EasyPact TVS offer**

**Power control & protection**

**Circuit control**

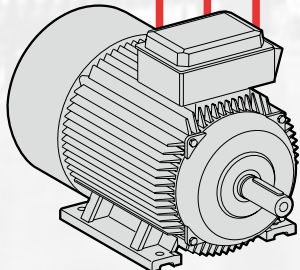
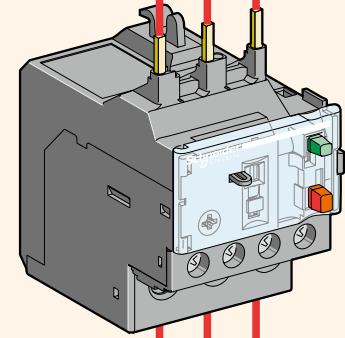
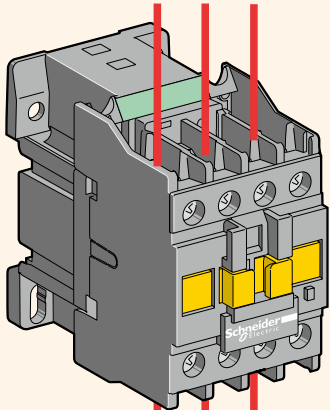
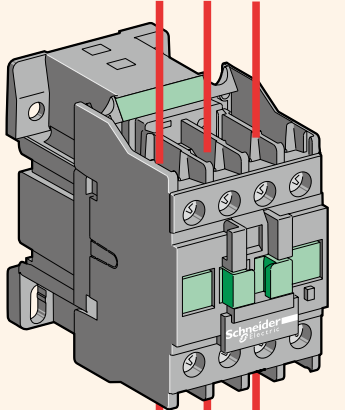

# EasyPact TVS 3 pole contactors



<b>Size</b>		1					2		3		
<b>Rated operational current AC-3</b>	<b>A</b>	6	9	12	18	25	32	38	40	50	65
<b>Rated operational current AC-1</b>	<b>A</b>	20	25		32	36	50		60	70	80
<b>Rated operational power in AC-3</b>	<b>220/230 V</b>	1.1	2.2	3	4	5.5	7.5	9	11	15	18.5
	<b>380/400 V</b>	2.2	4	5.5	7.5	11	15	18.5	18.5	22	30
	<b>415/440 V</b>	2.2	4	5.5	9	11	15	18.5	22	25/30	37
	<b>500 V</b>	3	5.5	7.5	10	15	18.5	18.5	22	30	37
	<b>660/690 V</b>	3	5.5	7.5	10	15	18.5	18.5	30	33	37
<b>Width</b>	<b>mm</b>	45					56		75		
<b>Coil rated operating voltage</b>		24...440 V AC according to the coil voltage code (see below)									
<b>Auxiliary built in contact</b>		1 NO or 1 NC							1 NO + 1 NC		
<b>References <sup>(1)</sup></b>		<b>LC1E06</b>	<b>LC1E09</b>	<b>LC1E12</b>	<b>LC1E18</b>	<b>LC1E25</b>	<b>LC1E32</b>	<b>LC1E38</b>	<b>LC1E40</b>	<b>LC1E50</b>	<b>LC1E65</b>

(1) Partial, see below.

### Coil voltage code

	24	48	110	220	240	380	415	440
50 Hz	B5	E5	F5	M5	U5	Q5	N5	R5
60 Hz	B6	-	F6	M6	-	Q6	-	R6
50/60Hz	-	E7	F7	M7	U7	Q7	N7	-

### Contactors: how to determine the full commercial reference ?

Example:

<b>LC1E</b>   <b>12</b>   <b>10</b>   <b>U</b>   <b>5</b>	<b>ref. LC1E1210U5</b>
5	50 Hz
Coil voltage code	240 V
Auxiliary contact configuration <sup>(2)</sup>	01 1NC 10 1NO N/A 1NO+1NC
Rated operation current AC3	12 A
Contactors	EasyPact TVS

Example 1: you need a 32 A contactor, 1 NC auxiliary contact, 24 V - 50 Hz



coil ⇒ **LC1E3201B5**

Example 2: you need a 120 A contactor, 1 NC + NO auxiliary contact, 220 V - 50 Hz

coil ⇒ **LC1E120M5**

<sup>(2)</sup> Only up to LC1E38.

# from 6 to 630 A

									
4	5	6	7	8	9				
80	95	120	160	200	250	300	400	500	630
110	120	150	200	250	300	320	500	700	1000
22	25	37	45	55	75	90	110	147	185
37	45	55	75	90	132	160	200	250	335
45	45	59	80	100	140	185/160	250/220	295/280	400/375
45	55	75	90	110	160	200	257	355	400
45	45	80	100	110	160	220	280	335	450
85		120		168.5		213	213	233	309
1 NO + 1 NC									
-									
LC1E80	LC1E95	LC1E120	LC1E160	LC1E200	LC1E250	LC1E300	LC1E400	LC1E500	LC1E630

## Common characteristics

> Contactors compatible with:



LAEN● auxiliary contact blocks  
(see page 16)



LAETSD time delay auxiliary contact (from 25 A contactor)  
(see page 16)



LAERC●● RC switch suppressor (up to 95 A)  
(see page 15)



LAEM● mechanical interlock  
(see page 15)



LAEP● set of power connections (up to 95 A)  
(see page 15)

## Utilisation categories

- > Class AC-1: AC loads with  $\cos \varphi$  at least equal to 0.95 (resistive load, heating, distribution, etc.).
- > Class AC-3: squirrel-cage motors with breaking taking place with the motor running.

# EasyPact TVS contactors

6 to 630 A

Power characteristics

Power circuit connections						
Contactor type			LC1E06	LC1E09	LC1E12	LC1E18
Number of poles			3			
Rated operational current (Ie) (Ue ≤ 440 V)	In AC-3 (θ ≤ 60 °C)	A	6	9	12	18
	In AC-3 (θ ≤ 55 °C)					
	In AC-1 (θ ≤ 60 °C)		20	25		32
	In AC-1 (θ ≤ 40 °C)		–			
Rated operational voltage (Ue)	Up to	V	690			
Frequency limits	Of the operational current	Hz	50/60			
Conventional thermal current (Ith)	θ ≤ 60 °C	A	20	25		32
	θ ≤ 40 °C		–			
Rated breaking capacity at 440 V	Conforming to IEC 60947	A	48	72	96	144
Rated making capacity at 440 V	Conforming to IEC 60947-4-1	A	60	90	120	180
Permissible short time rating No current flowing for preceding 15 minutes with θ ≤ 40 °C	10 s	A	80	105		145
	1 min		45	61		84
	10 min		20	30		40
Maximum permissive current No current flowing for previous 60 minutes, at θ ≤ 40 °C	For 10 s	A	–			
Protection by fuses against short-circuits (U ≤ 690 V)	Without thermal overload relay gG fuse Type 1	A	12	20	25	35
	With thermal overload relay		For corresponding aM or gG fuse ratings corresponding to the associated LRE thermal overload relay, please see page 33			
Average impedance per pole	At Ith and 50 Hz	mΩ	2.5			
Power dissipation per pole for the above operational currents	AC-3	W	0.09	0.20	0.36	0.81
	AC-1		1.0	1.6		2.6
Electrical durability	AC-3 (Ue ≤ 440 V)	Million cycles	1.4			1.2
	AC-1 (Ue ≤ 440 V)		0.15		0.3	
	AC-4 (Ue ≤ 440 V)		0.04			0.035
Mechanical durability			10			

Power circuit connections				
Connection maximum c.s.a.				
Flexible cable with cable end	1 conductor	mm <sup>2</sup>	1...4	
	2 conductors		1...2.5	
Solid cable without cable end	1 conductor	mm <sup>2</sup>	1...4	1.5...6
	2 conductors		1...4	1.5...6
Cable with lug		mm	–	
Bar	Number of bars		–	
	Bar	mm x mm	–	
Bolt diameter	1 conductor	mm	–	
Tightening torque	Power circuit connection	N.m	1.2	
Tool			Philips N°2 or Ø6mm flat	

	LC1E25	LC1E32	LC1E38	LC1E40	LC1E50	LC1E65	LC1E80	LC1E95	LC1E120	LC1E160	LC1E200	LC1E250	LC1E300	LC1E400	LC1E500	LC1E630
	25	32	38	40	50	65	80	95	–							
									120	160	200	250	300	400	500	630
	36	50		60	70	80	110	120	–							
									150	200	250	300	320	500	700	1000
	36	50		60	70	80	110	120	–							
									150	200	250	300	320	500	700	1000
	200	256	304	320	400	520	640	760	960	1280	1600	2000	2400	3200	4000	5040
	250	320	380	400	500	650	800	950	1200	1600	2000	2500	3000	4000	5000	6300
	240	260	310	320	400	520	640	800	–							
	120	138	150	165	208	260	320	400	–							
	50	60		72	84	110	135		–							
									1100	1400	1500	1800	2200	3600	4200	5050
	40	63		80	100	125	160		250	315			500	630	800	800
									–							
	2.5			1.5		1	0.8		0.6		0.33	0.32	0.3	0.26	0.18	0.12
	1.6	2.0	2.9	2.4	3.8	4.2	5.1	7.2	8.6	15	13	20	27	42	45	48
	3.2	5.0		5.4	7.4	6.4	9.7	12	14	24	21	29	31	65	88	120
		1	0.9						0.8					0.909	1.17	0.743
	0.35								0.25					0.323	0.375	0.207
		0.03	0.025						0.012	0.007	0.006	0.005		0.014	0.016	0.016
		8		5			3		4		5			10	10	5
	1...6			2.5...25			4...50		10...120							–
	1...4			2.5...10			4...16		10...120 + 10...50							–
				2.5...25			4...50		10...120							–
				2.5...16			4...50		10...120 + 10...50							–
										150	185	240	2 x 150	2 x 240		–
										2						
										3 x 25	4 x 32	5 x 30	30 x 5	40 x 5	60 x 5	
										M8	M10				M12	
	1.5	2.1		5			9		12	18	35					58
				Ø8mm flat			Ø8mm flat or Allen key n°4		Allen key n°4							Wrench

# EasyPact TVS contactors

6 to 630 A

Control circuit: coil characteristics

Built in auxiliary contact

Control circuit: coil characteristics with a.c. supply					
Contactor type		LC1E06	LC1E09	LC1E12	LC1E18
Rated control circuit voltage (Uc) 50/60 Hz	V	24...440 according coil voltage code			
Control voltage limits ( $\theta \leq 55^\circ\text{C}$ )	50 Hz or 60 Hz coils Operational	0.85...1.1 U <sub>c</sub>			
	Drop-out	0.3...0.6 U <sub>c</sub>			
Average consumption at 20°C and at U <sub>c</sub>					
~ 50 Hz coils	Inrush	coil	VA	95	
		cos $\varphi$		0.75	
	Sealed	coil	VA	8.5	
		cos $\varphi$		0.3	
~ 60 Hz coils	Inrush	coil	VA	95	
		cos $\varphi$		0.75	
	Sealed	coil	VA	8.5	
		cos $\varphi$		0.3	
Heat dissipation	W	2.3			
Operating time	Closing "C"	ms	12...22		
	Opening "O"		4...19		
Electrical durability (AC-3)	AC-3 (U <sub>e</sub> ≤ 440 V)	In millions of operating cycles	1.2...1.4		
	AC-1 (U <sub>e</sub> ≤ 440 V)		-		
Mechanical durability at U <sub>c</sub>			10		
Maximum operating rate at ambient temperature ≤ 60 °C		In operating cycles per hour	1800		
Maximum operating rate at ambient temperature ≤ 55 °C			-		

Control circuit connections				
Connection maximum c.s.a.				
Flexible cable without cable end	1 or 2 conductors	mm <sup>2</sup>	1...4	
Flexible cable with cable end	1 conductor	mm <sup>2</sup>	1...4	
	2 conductors		1...2.5	
Solid cable without cable end	1 or 2 conductors	mm <sup>2</sup>	1...4	
Tightening torque		N.m	1.7	
Screwdriver			Philips N° 2 - Ø6 mm flat	

Built in auxiliary contact				
Contacts conforming to	IEC 60947-5-1		LC1E06...E38: contactor's own 1NO or 1NC LC1E40...E160: contactor's own 1NO and 1NC	
Rated operational voltage (U <sub>e</sub> )	Up to	V	690	
Rated insulation voltage (U <sub>i</sub> )	Conforming to IEC 60947-1		690	
Conventional thermal current (I <sub>th</sub> )	Ambient air temperature ≤ 60 °C	A	10	
Operating current frequency		Hz	50/60 Hz	
Minimum switching capacity $\lambda = 10^{-8}$	U min	V	17	
	I min	mA	5	
Short-circuit protection	Conforming to IEC 60947-5-1		gG fuse: 10 A	
Raked making capacity	Conforming to IEC 60947-5-1	A	~: 140	
Short-time rating	Permissible for	1 s	A	100
		500 ms		120
		100 ms		140
Insulation resistance		MΩ	>10	
Non-overlap time	Guaranteed between N/C and N/O contacts	ms	1.5 on energisation and on de-energisation	





# EasyPact TVS contactors

## 6 to 630 A

Environment				LC1E06...E18	LC1E25...E38
Contactor type					
Rated insulation voltage (Ui)	Conforming to IEC 60947-4-1, overvoltage category III, degree of pollution: 3	V	690		
Rated impulse withstand voltage (Uimp)	Conforming to IEC 60947	kV	6		
Conforming to standards			IEC 60947-4-1, IEC 60947-5-1		
Product certifications			GOST		
Degree of protection	Conforming to IEC 60529		IP20		
Protective treatment	Conforming to IEC 60068		"TH"		
Ambiant air temperature around the device	Storage	°C	-60...+80		
	Operation		-5...+55		
	Permissible at UC <sup>(2)</sup>		-20...+70		
Maximum operating altitude	Without derating	m	3000		
Operating positions	Without derating		±30° in relation to normal vertical mounting plane		
Flame resistance	Conforming to IEC 60695-2-1	°C	850 °C		
Shock resistance <sup>(3)</sup>	Contactor open		7 gn	6 gn	
1/2 sinewave = 11 ms	Contactor closed		10 gn		
Vibration resistance <sup>(3)</sup>	Contactor open		1.5 gn		
5...300 Hz	Contactor closed		3 gn		

(1) Derating, please call your regional sales.

(2) Derating see page 49.

(3) Without change of contact states, in the most unfavorable direction (coil energised at Ue).

### Installation recommendations



#### Avoid fire, product damage or power loss with a safe enclosure

Severe conditions such as dust, humidity, high temperature can result in people or equipments exposed to serious risks if the suitable protection of the electrical components is not taken.

#### Spacial CRN steel enclosures is one of our solutions

A complete offer with 39 dimensions from 200 x 200 x 150 mm to 1000 x 800 x 300 mm:

- with plain door, without plain mounting plate
- with plain door and plain mounting plate
- with glazed door, without plain mounting plate.

- Degree of protection IP 66.
- Compliance with standard IEC 62208.
- A wide range of accessories to fit to all your applications.

#### Spacial CRN, suitable for any application

Indoors with harsh and dirty environments like machines, manufacturing plants, and logistic centers.

Specific optional devices re-enforce the protection: fans, filters.



# EasyPact TVS contactors

## EasyPact TVS contactors for motor control up to 335 kW at 400 V, in category AC-3



3-pole contactors						Rated operational current in AC-3 440 V up to	Instantaneous auxiliary contacts		Basic reference, to be completed by adding the control voltage code	Weight
Standard power ratings of 3-phase motors 50/60 Hz in category AC-3					A					
220 V	380 V									
230 V	400 V	415 V	500 V	690 V						
kW	kW	kW	kW	kW						
<b>Connection by screw clamp terminals</b>										
1.1	2.2	2.2	3	3	6	1	0	LC1E0610●●	0.300	
1.1	2.2	2.2	3	3	6	0	1	LC1E0601●●	0.300	
2.2	4	4	5.5	5.5	9	1	0	LC1E0910●●	0.300	
2.2	4	4	5.5	5.5	9	0	1	LC1E0901●●	0.300	
3	5.5	5.5	7.5	7.5	12	1	0	LC1E1210●●	0.300	
3	5.5	5.5	7.5	7.5	12	0	1	LC1E1201●●	0.300	
4	7.5	9	10	10	18	1	0	LC1E1810●●	0.300	
4	7.5	9	10	10	18	0	1	LC1E1801●●	0.300	
5.5	11	11	15	15	25	1	0	LC1E2510●●	0.360	
5.5	11	11	15	15	25	0	1	LC1E2501●●	0.360	
7.5	15	15	18.5	18.5	32	1	0	LC1E3210●●	0.450	
7.5	15	15	18.5	18.5	32	0	1	LC1E3201●●	0.450	
9	18.5	18.5	18.5	18.5	38	1	0	LC1E3810●●	0.450	
9	18.5	18.5	18.5	18.5	38	0	1	LC1E3801●●	0.450	
11	18.5	22	22	30	40	1	1	LC1E40●●	0.980	
15	22	25/30	30	33	50	1	1	LC1E50●●	0.980	
18.5	30	37	37	37	65	1	1	LC1E65●●	0.980	
22	37	45	45	45	80	1	1	LC1E80●●	1.520	
25	45	45	55	45	95	1	1	LC1E95●●	1.520	
37	55	55	75	75	120	1	1	LC1E120●●	2.300	
45	90	90	90	90	160	1	1	LC1E160●●	2.300	
<b>Connection by bars</b>										
55	110	110	110	110	200	0	0	LC1E200●●	4.600	
75	132	132	132	132	250	0	0	LC1E250●●	4.700	
90	160	160	160	160	300	0	0	LC1E300●●	8.500	
110	200	220	257	280	400	0	0	LC1E400●●	9.1	
147	250	280	355	335	500	0	0	LC1E500●●	11.35	
200	335	375	400	450	630	0	0	LC1E630●●	18.6	

Control voltage code								
Volts	24	48	110	220	240	380	415	440
<b>LC1E06...630</b>								
50 Hz	B5	E5	F5	M5	U5	Q5	N5	R5
60 Hz	B6	-	F6	M6	-	Q6	-	R6
50/60Hz	-	E7	F7	M7	U7	Q7	N7	-

### Separate components

Auxiliary contact blocks, add-on modules and accessories, see pages 15 to 17.

### Coil spare parts

For maintenance, each coil can be ordered separately, see page 18 to 21.

(1) LC1E06 to E65: clip-on mounting on 35 mm rail AM1 DP or screw fixing.  
 LC1E80 to E95: clip-on mounting on 35 mm rail AM1DP or 75 mm rail AM1 DL or screw fixing.  
 LC1E120 and E160: clip-on mounting on 2 x 35 mm rail AM1 DP or screw fixing.

# Accessories for LC1E contactor

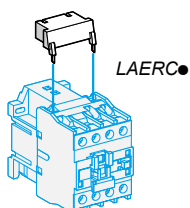
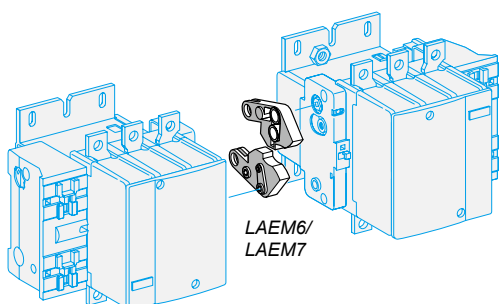
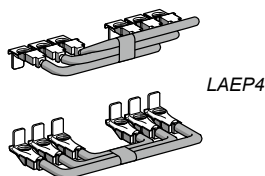
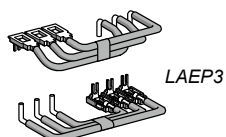
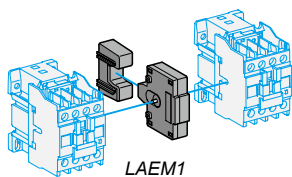

LC1E

## Accessories for motor reverse assembly

Contactors with screw clamp terminals

Using 2 identical contactors	Set of power connections		Mechanical interlock	
	Cat. no.	Weight kg	Cat. no.	Weight kg
<b>Mechanical interlock</b>				
LC1E06...E12	LAEP1	0.020	LAEM1	0.030
LC1E18/E25	LAEP12	0.026	LAEM1	0.030
LC1E32/E38	LAEP2	0.040	LAEM1	0.030
LC1E40...E65	LAEP3	0.230	LAEM1	0.030
LC1E80/E95	LAEP4	0.465	LAEM4	0.095
LC1E120/E160	– (DIY) <sup>(1)</sup>		LAEM5	0.300
LC1E200/E250	– (DIY) <sup>(1)</sup>		LAEM6	0.110
LC1E300	– (DIY) <sup>(1)</sup>		LAEM7	0.250
LC1E400	– (DIY) <sup>(1)</sup>		LAEM8	0.14
LC1E500	– (DIY) <sup>(1)</sup>		LAEM9	0.14
LC1E630	– (DIY) <sup>(1)</sup>		LAEM10	0.15

(1) DIY : Do It Yourself.

## RC surge suppressor

- Effective protection for circuits highly sensitive to "high frequency" interference and transient generated when the contactor coil is switched off. For use only in cases where the voltage is virtually sinusoidal, i.e. less than 5 % total harmonic distortion.
- Voltage limited to 3 Uc max. and oscillating frequency limited to 400 Hz max.
- Slight increase in drop-out time (1.2 to 2 times the normal time).

Mounting	For use with contactor		Cat. no.	Weight kg
	Rating	Type		
Screw mounting	LC1E06...E95	V~		
		24...48	LAERCE	0.025
		50...127	LAERCG	0.025
		110...240	LAERCU	0.025
		380...415	LAERCN	0.025

# EasyPact TVS contactors

## Accessories for LC1E contactor



LAEN22



LAETSD

### Instantaneous auxiliary contact blocks for connection by screw lamps terminals

For use in normal operating environment

Clip-on mounting	Number of contacts per block	Cat. no.	Weight kg
Front	1 NO / 1 NC	LAEN11	0.035
	2 NO	LAEN20	0.035
	2 NC	LAEN02	0.035
	2 NO / 2 NC	LAEN22	0.060

### Time delay auxiliary contact blocks for connection by screw clamp terminals 8 A - 690 V

Clip-on mounting	Number of contacts per block	Time delay Type	Setting range	Cat. no. <sup>(1)</sup>	Weight kg
Front	1 NO / 1 NC	On-delay	1...30 s	LAETSD	0.060

<sup>(1)</sup> For use only LC1E25 to LC1E630.

### Instantaneous and time delay contact characteristics

Contact block type			LAEN11, 20, 02, 22			LAETSD			
Number of contacts			2 or 4			2			
Rated operational voltage (Ue) Up to		<b>V</b>	690						
Rated insulation voltage (Ui) Conforming to IEC 60947-5-1			690						
Conventional thermal current (Ith) For ambient temperature $\theta \leq 60^\circ\text{C}$		<b>A</b>	8						
Frequency of the operational current		<b>Hz</b>	50/60						
Minimum switching capacity		<b>U min</b>	17						
		<b>I min</b>	5						
Short-circuit protection Conforming to IEC 60947-5-1		<b>A</b>	10						
Rated making capacity Conforming to IEC 60947-5-1		<b>I<sub>rms</sub></b>	~ 140						
Short-time rating Permissible for		1 s	100						
		500 ms	120						
		100 ms	140						
Insulation resistance		<b>mΩ</b>	> 10						
Non-overlap time Guaranteed between NC and NO contacts		<b>ms</b>	1.5 (on energisation and on de-energisation)						
Overlap time Guaranteed between LAE N22 N/C and N/O contacts		<b>ms</b>	-						
Time delay		Ambient air temperature for operation	-			-20...+70			
		Repeat accuracy	-			±2 %			
		Drift up to 0.5 million operating cycles	-			+15 %			
		Drift depending on ambient air temperature	-			0.25 % per °C			
Mechanical durability		<b>In millions of operating cycles</b>	10			4			
Rated operational power of contacts (Conforming to IEC 60947-5-1)		a.c. supply categories AC14/15	<b>V</b>	24	48	115	230	400	440
		1 million operating cycles	<b>VA</b>	60	120	280	560	960	1050
		3 million operating cycles		16	32	80	160	280	300
		10 million operating cycles		4	8	20	4	70	80

## Accessories for LC1E

Environment				
Contact block type			LAEN11, 20, 02, 22	LAETSD
Conforming to standard			IEC 60947-5-1	
Product certifications			GOST	
Protective treatment	Conforming to IEC 60068		"TH"	
Degree of protection	Conforming to IEC 60529		IP20	
Ambiant air temperature	Storage	°C	-60...+80	
	Operation		-5...+55	
	Permissible for operation at Uc		-20...+70	
Maximum operating altitude	Without derating	m	3000	
Connection by cable	Philips N° 2 and Ø 6 mm. Flexible or solid cable with or without cable end	mm <sup>2</sup>	Min: 1 x 1 Max: 2 x 2.5	

Accessories compatibility						
Contactor	Built in contacts	LAEN●●	LAETSD	LAERC●	LAEM	LAEP●
LC1E06	1 NO or 1NC	1	-			
LC1E09						
LC1E12						
LC1E18						
LC1E25	1 NO + 1NC	1	or 1	1	1	1
LC1E32						
LC1E38						
LC1E40						
LC1E50						
LC1E65						
LC1E80	-	2	or 0	-		DIY <sup>(1)</sup>
LC1E95						
LC1E120						
LC1E160						
LC1E200	-	1	or 1			
LC1E250						
LC1E300						
LC1E400						
LC1E500						
LC1E630						

(1) Do It Yourself.

# EasyPact TVS contactors

## Coil replacement for EasyPact TVS, LC1E06 to E38

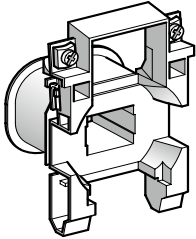

LAEX1●●

### For 3-pole contactors LC1E06...E18

#### Specifications

Average consumption at 20 °C:

■ inrush ( $\cos \varphi = 0.75$ ) 50 Hz: 95 VA; 60 Hz: 95 VA

■ sealed ( $\cos \varphi = 0.3$ ) 50 Hz: 8.5 VA; 60 Hz: 8.5 VA

Operating range ( $\theta \leq 55$  °C): 0.85...1.1 Uc.

Control circuit voltage Uc	Average resistance at 20 °C ±10 %	Inductance of closed circuit	Cat. no. <sup>(1)</sup>		Average resistance at 20 °C ±10 %	Inductance of closed circuit	Cat. no. <sup>(1)</sup>		Weight
			50 Hz	60 Hz			50 Hz	60 Hz	
V	Ω	H	50 Hz	60 Hz	Ω	H	50 Hz	60 Hz	kg
24	8.70	0.24	LAEX1B5	LAEX1B6	7.80	0.15	LAEX1B5	LAEX1B6	0.056
48	37.0	1.00	LAEX1E5	-	-	-	-	-	0.056
110	190	4.64	LAEX1F5	LAEX1F6	170	3.07	LAEX1F5	LAEX1F6	0.056
220	750	19.7	LAEX1M5	LAEX1M6	690	11.6	LAEX1M5	LAEX1M6	0.056
240	890	23.4	LAEX1U5	-	-	-	-	-	0.056
380	2250	58.3	LAEX1Q5	LAEX1Q6	2110	35.4	LAEX1Q5	LAEX1Q6	0.056
415	2610	69.0	LAEX1N5	-	-	-	-	-	0.056
440	2690	78.2	LAEX1R5	LAEX1R6	2760	50.7	LAEX1R5	LAEX1R6	0.056

### For 3-pole contactors LC1E25

#### Specifications

Average consumption at 20 °C:

■ inrush ( $\cos \varphi = 0.75$ ) 50 Hz: 70 VA; 60 Hz: 70 VA

■ sealed ( $\cos \varphi = 0.3$ ) 50 Hz: 7 VA; 60 Hz: 7.5 VA

Operating range ( $\theta \leq 55$  °C): 0.85...1.1 Uc.

Control circuit voltage Uc	Average resistance at 20 °C ±10 %	Inductance of closed circuit	Cat. no. <sup>(1)</sup>		Average resistance at 20 °C ±10 %	Inductance of closed circuit	Cat. no. <sup>(1)</sup>		Weight
			50 Hz	60 Hz			50 Hz	60 Hz	
V	Ω	H	50 Hz	60 Hz	Ω	H	50 Hz	60 Hz	kg
24	5.37	0.21	LAEX12B5	LAEX12B6	5.37	0.18	LAEX12B5	LAEX12B6	0.067
48	21.7	0.84	LAEX12E5	-	-	-	-	-	0.067
110	124	4.41	LAEX12F5	LAEX12F6	124	3.68	LAEX12F5	LAEX12F6	0.067
220	515	17.6	LAEX12M5	LAEX12M6	516	14.7	LAEX12M5	LAEX12M6	0.067
240	562	21.0	LAEX12U5	-	-	-	-	-	0.067
380	1550	52.6	LAEX12Q5	LAEX12Q6	1550	43.8	LAEX12Q5	LAEX12Q6	0.067
415	1690	62.8	LAEX12N5	-	-	-	-	-	0.067
440	1990	70.6	LAEX12R5	LAEX12R6	1990	58.9	LAEX12R5	LAEX12R6	0.067

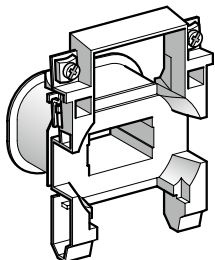

LAEX2●●

### For 3-pole contactors LC1E32/E38

#### Specifications

Average consumption at 20 °C:

■ inrush ( $\cos \varphi = 0.75$ ) 50 Hz: 70 VA; 60 Hz: 70 VA

■ sealed ( $\cos \varphi = 0.3$ ) 50 Hz: 7 VA; 60 Hz: 7.5 VA

Operating range ( $\theta \leq 55$  °C): 0.85...1.1 Uc.

Control circuit voltage Uc	Average resistance at 20 °C ±10 %	Inductance of closed circuit	Cat. no. <sup>(1)</sup>		Average resistance at 20 °C ±10 %	Inductance of closed circuit	Cat. no. <sup>(1)</sup>		Weight
			50 Hz	60 Hz			50 Hz	60 Hz	
V	Ω	H	50 Hz	60 Hz	Ω	H	50 Hz	60 Hz	kg
24	5.37	0.21	LAEX2B5	LAEX2B6	5.37	0.18	LAEX2B5	LAEX2B6	0.073
48	21.7	0.84	LAEX2E5	-	-	-	-	-	0.073
110	124	4.41	LAEX2F5	LAEX2F6	124	3.68	LAEX2F5	LAEX2F6	0.073
220	515	17.6	LAEX2M5	LAEX2M6	516	14.7	LAEX2M5	LAEX2M6	0.073
240	562	21.0	LAEX2U5	-	-	-	-	-	0.073
380	1550	52.6	LAEX2Q5	LAEX2Q6	1550	43.8	LAEX2Q5	LAEX2Q6	0.073
415	1690	62.8	LAEX2N5	-	-	-	-	-	0.073
440	1990	70.6	LAEX2R5	LAEX2R6	1990	58.9	LAEX2R5	LAEX2R6	0.073

(1) The last two digits in the reference represent the voltage code.



# Coil replacement for EasyPact TVS, LC1E40 to E160

## For 3-pole contactors LC1E40...E65

### Specifications

Average consumption at 20 °C:

■ inrush ( $\cos \varphi = 0.75$ ): 50 Hz: 160 VA; 60 Hz: 140 VA

■ sealed ( $\cos \varphi = 0.3$ ) 50 Hz: 15 VA; 60 Hz: 13 VA

Operating range ( $\theta \leq 60$  °C): 0.85...1.1 Uc

Control circuit voltage Uc	Average resistance at 20 °C $\pm 10$ %	Inductance of closed circuit	Cat. no. <sup>(1)</sup>	Average resistance at 20 °C $\pm 10$ %	Inductance of closed circuit	Cat. no. <sup>(1)</sup>	Weight
V	$\Omega$	H	50 Hz	$\Omega$	H	60 Hz	kg
24	1.98	0.12	LAEX3B5	1.98	0.10	LAEX3B6	0.110
48	7.97	0.48	LAEX3E5	-	-	-	0.110
110	42.3	2.51	LAEX3F5	42.3	2.09	LAEX3F6	0.110
220	182	10.0	LAEX3M5	182	8.36	LAEX3M6	0.110
240	202	12.0	LAEX3U5	-	-	-	0.110
380	512	30.3	LAEX3Q5	512	25.3	LAEX3Q6	0.110
415	635	35.8	LAEX3N5	-	-	-	0.110
440	682	40.1	LAEX3R5	682	33.4	LAEX3R6	0.110

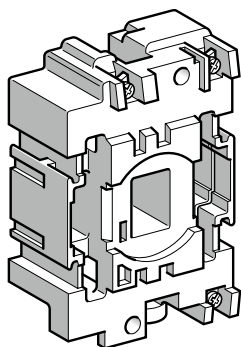

LAEX4●●

## For 3-pole contactors LC1E80/E95

### Specifications

Average consumption at 20 °C:

■ inrush ( $\cos \varphi = 0.75$ ) 50 Hz: 200 VA; 60 Hz: 220 VA

■ sealed ( $\cos \varphi = 0.3$ ) 50 Hz: 20 VA; 60 Hz: 22 VA

Operating range ( $\theta \leq 55$  °C): 0.85...1.1 Uc.

Control circuit voltage Uc	Average resistance at 20 °C $\pm 10$ %	Inductance of closed circuit	Cat. no. <sup>(1)</sup>	Average resistance at 20 °C $\pm 10$ %	Inductance of closed circuit	Cat. no. <sup>(1)</sup>	Weight
V	$\Omega$	H	50 Hz	$\Omega$	H	60 Hz	kg
24	1.4	0.09	LAEX4B5	1.05	0.06	LAEX4B6	0.145
48	5.5	0.35	LAEX4E5	-	-	-	0.145
110	31.0	1.90	LAEX4F5	22.0	1.20	LAEX4F6	0.145
220	127	7.50	LAEX4M5	98	4.80	LAEX4M6	0.145
240	152	8.70	LAEX4U5	-	-	-	0.145
380	381	22.0	LAEX4Q5	300	14.0	LAEX4Q6	0.145
415	463	26.0	LAEX4N5	-	-	-	0.145
440	513	30.0	LAEX4R5	392	19.0	LAEX4R6	0.145

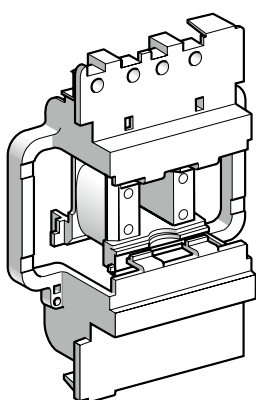

LAEX5●●

## For 3-pole contactors LC1E120/E160

### Specifications

Average consumption at 20 °C:

■ inrush ( $\cos \varphi = 0.8$ ) 50 Hz: 300 VA

■ sealed ( $\cos \varphi = 0.8$ ) 50 Hz: 22 VA

Operating range ( $\theta \leq 55$  °C): 0.85...1.1 Uc.

Control circuit voltage Uc	Average resistance at 20 °C $\pm 10$ %	Inductance of closed circuit	Cat. no. <sup>(1)</sup>	Average resistance at 20 °C $\pm 10$ %	Inductance of closed circuit	Cat. no. <sup>(1)</sup>	Weight
V	$\Omega$	H	50 Hz	$\Omega$	H	60 Hz	kg
24	1.24	0.09	LAEX5B5	0.87	0.07	LAEX5B6	0.210
48	4.51	0.36	LAEX5E5	-	-	-	0.210
110	26.5	2.00	LAEX5F5	20.0	1.45	LAEX5F6	0.210
220	105	7.65	LAEX5M5	79.6	5.69	LAEX5M6	0.210
240	125	8.89	LAEX5U5	-	-	-	0.210
380	339	22.3	LAEX5Q5	243	17.0	LAEX5Q6	0.210
415	368	27.7	LAEX5N5	-	-	-	0.210
440	442	30.3	LAEX5R5	339	22.3	LAEX5R6	0.210

(1) The last two digits in the reference represent the voltage code.

# EasyPact TVS contactors

## Coil replacement for EasyPact TVS, LC1E200 to E300

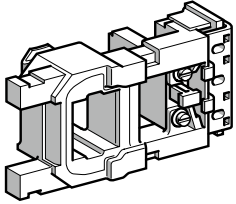

LAEX6●●

### For 3-pole contactors LC1E200...E250

#### Specifications

Average consumption at 20 °C:

■ inrush ( $\cos \varphi = 0.9$ ) 50 Hz: 805 VA; 60 Hz: 970 VA

■ sealed ( $\cos \varphi = 0.3$ ) 50 Hz: 55 VA; 60 Hz: 66 VA

Heat dissipation: 18...24 W.

Operating time à  $U_c$ : closing = 20...35 ms, opening = 7...15 ms.

Control circuit voltage $U_c$	Average resistance at 20 °C ±10 %	Inductance of closed circuit	Cat. no. <sup>(1)</sup>	Average resistance at 20 °C ±10 %	Inductance of closed circuit	Cat. no. <sup>(1)</sup>	Weight
V	Ω	H	50 Hz	Ω	H	60 Hz	kg
24	0.18	0.03	LAEX6B5	0.13	0.02	LAEX6B6	0.510
48	0.71	0.12	LAEX6E5	-	-	-	0.510
110	4.2	0.65	LAEX6F5	2.7	0.44	LAEX6F6	0.510
220	17	2.59	LAEX6M5	11.1	1.80	LAEX6M6	0.510
240	20	3.09	LAEX6U5	-	-	-	0.510
380	51.3	7.8	LAEX6Q5	34	5.3	LAEX6Q6	0.510
415	62.3	9.1	LAEX6N5	-	-	-	0.510
440	62.3	9.1	LAEX6R5	43.5	6.9	LAEX6R6	0.510

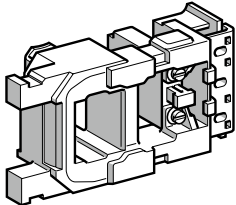

LAEX7●●

### For 3-pole contactors LC1E300

#### Specifications

Average consumption at 20 °C:

■ inrush ( $\cos \varphi = 0.9$ ) 50 Hz or 60 Hz: 650 VA

■ sealed ( $\cos \varphi = 0.3$ ) 50 Hz or 60 Hz: 10 VA.

Heat dissipation: 8 W.

Operating time à  $U_c$ : closing = 40...65 ms, opening = 100...170 ms.

Operate on networks with harmonic numbers ≤ 7.

Operating cycles/hour ( $\theta \leq 55$  °C): ≤ 2400

Control circuit voltage $U_c$	Average resistance at 20 °C ±10 %	Inductance of closed circuit	Cat. no. <sup>(1)</sup>	Average resistance at 20 °C ±10 %	Inductance of closed circuit	Cat. no. <sup>(1)</sup>	Weight
V	Ω	H	50 Hz	Ω	H	60 Hz	kg
24	20	<sup>(2)</sup>	LAEX7B5	20	<sup>(2)</sup>	LAEX7B6	0.770
48	67	<sup>(2)</sup>	LAEX7E5	-	-	-	0.770
110	440	<sup>(2)</sup>	LAEX7F5	440	<sup>(2)</sup>	LAEX7F6	0.770
220	1578	<sup>(2)</sup>	LAEX7M5	1578	<sup>(2)</sup>	LAEX7M6	0.770
240	1968	<sup>(2)</sup>	LAEX7U5	-	-	-	0.770
380	4631	<sup>(2)</sup>	LAEX7Q5	4631	<sup>(2)</sup>	LAEX7Q6	0.770
415	4631	<sup>(2)</sup>	LAEX7N5	-	-	-	0.770
440	6731	<sup>(2)</sup>	LAEX7R5	6731	<sup>(2)</sup>	LAEX7R6	0.770

<sup>(1)</sup> The last two digits in the reference represent the voltage code.

<sup>(2)</sup> Please consult your Regional Sales Office.

# Coil replacement for EasyPact TVS, LC1E400 to E630

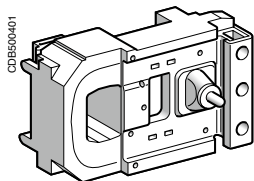

LAEX8●●

## For 3-pole contactors LC1E400

Average consumption at 20 °C:

■ inrush ( $\cos \varphi = 0.9$ ) 50Hz or 60Hz: 1000...1150

■ sealed ( $\cos \varphi = 0.9$ ) 50Hz or 60Hz: 12...18VA

Heat dissipation : 14W

Operation time à  $U_c$ : closing=40...75ms, opening=100...170ms

Operating cycles/hour ( $\theta \leq 55$  °C):  $\leq 2400$

Control circuit voltage $U_c$	Average resistance at 20 °C $\pm 10$ %	Inductance of closed circuit	Cat. no.	Average resistance at 20 °C $\pm 10$ %	Inductance of closed circuit	Cat. no.	Weight
V	$\Omega$	H	50 Hz	$\Omega$	H	60 Hz	kg
48	29.5	0.18		-	-		1
110	230	1.35		230	1.35		1
220	1030	5.1		1030	5.1		1
240	1320	6.4		-	-		1
380	3310	15.8		3310	15.8		1
415	4070	19.4		-	-		1
440	4070	19.4		4070	19.4		1

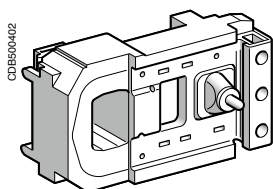

LAEX9●●

## For 3-pole contactors LC1E500

Average consumption at 20 °C:

■ inrush ( $\cos \varphi = 0.9$ ) 50Hz or 60Hz: 1050...1150A

■ sealed ( $\cos \varphi = 0.9$ ) 50Hz or 60Hz: 16...20VA

Heat dissipation : 18W

Operation time à  $U_c$ : closing=40...75ms, opening=100...170ms

Operating cycles/hour ( $\theta \leq 55$  °C):  $\leq 2400$

Control circuit voltage $U_c$	Average resistance at 20 °C $\pm 10$ %	Inductance of closed circuit	Cat. no.	Average resistance at 20 °C $\pm 10$ %	Inductance of closed circuit	Cat. no.	Weight
V	$\Omega$	H	50 Hz	$\Omega$	H	60 Hz	kg
48	33.5	0.19		-	-		1.15
110	260	1.25		258	1.25		1.15
220	915	4.55		916	4.55		1.15
240	1160	5.75		-	-		1.15
380	2980	14.7		2981	14.7		1.15
415	3730	18.4		-	-		1.15
440	3730	18.4		3733	18.4		1.15

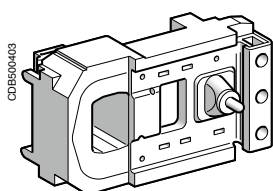

LAEX10●●

## For 3-pole contactors LC1E630

Average consumption at 20 °C:

■ inrush ( $\cos \varphi = 0.9$ ) 50Hz or 60Hz: 1500...1730VA

■ sealed ( $\cos \varphi = 0.9$ ) 50Hz or 60Hz: 20...25VA

Heat dissipation : 20W

Operation time à  $U_c$ : closing=40...80ms, opening=100...200ms

Operating cycles/hour ( $\theta \leq 55$  °C):  $\leq 1200$

Control circuit voltage $U_c$	Average resistance at 20 °C $\pm 10$ %	Inductance of closed circuit	Cat. no.	Average resistance at 20 °C $\pm 10$ %	Inductance of closed circuit	Cat. no.	Weight
V	$\Omega$	H	50 Hz	$\Omega$	H	60 Hz	kg
48	17.1	0.09		-	-		1.5
110	165	1.85		165	1.85		1.5
220	730	3.35		730	3.35		1.5
240	730	3.35		-	-		1.5
380	2360	10.5		2360	10.5		1.5
415	2960	13		-	-		1.5
440	2960	13		2960	13		1.5

# EasyPact TVS contactors

## Replacement contacts for EasyPact TVS, LC1E120 to E630

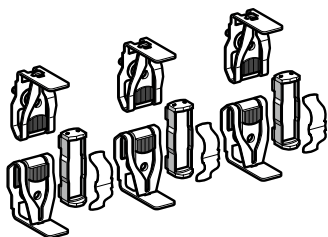

LAEC6

### Sets of contacts

Per pole: 2 fixed contacts, 1 moving contact, 2 deflectors, 1 back-plate, clamping screws and washers.

For contactor	Type	Replacement for	Cat. no. 50 Hz	Weight kg
3-pole	LC1E120	3 poles	<b>LAEC5</b>	0.350
	LC1E160	3 poles	<b>LAEC51</b>	0.350
	LC1E200	3 poles	<b>LAEC6</b>	0.350
	LC1E250	3 poles	<b>LAEC61</b>	0.660
	LC1E300	3 poles	<b>LAEC7</b>	2.000
	LC1E400	3 poles	<b>LAEC71</b>	2
	LC1E500	3 poles	<b>LAEC8</b>	2.95
	LC1E630	3 poles	<b>LAEC9</b>	6.1

### LC1E06...E25

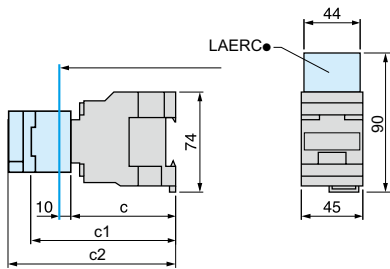

LC1	E06...E18	E25
c	80	85
c1 with LAEN	113	118
c2 with LAETSD	-	136

### LC1E32/38

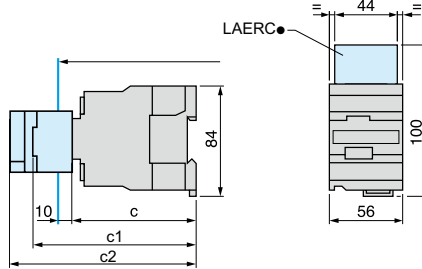

LC1	E32/38
c	86
c1 with LAEN	120
c2 with LAETSD	138

### LC1E06...E25

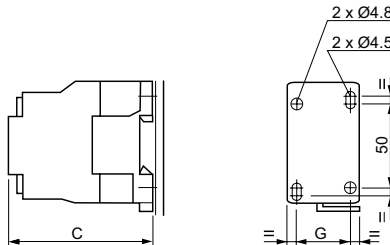

LC1	E06	E09	E12	E18	E25
c	80	80	80	80	85
G	35	35	35	35	35

### LC1E32/38

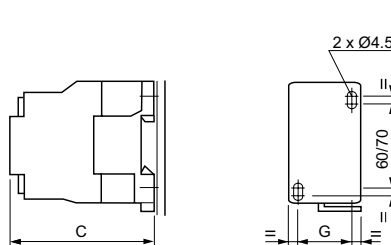

LC1	E32/38
c	86
G	40

### LC1E40...E65

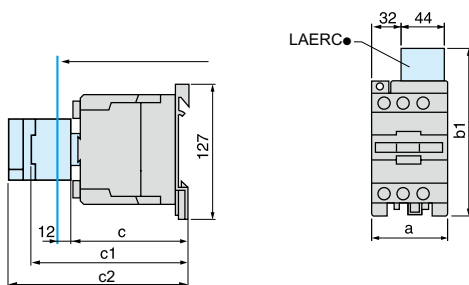

LC1	E40...E65
a	75
b1	with LAERC● 135
c	114
c1	with LAEN● 147
c2	with LAETSD 165

### LC1E80/95

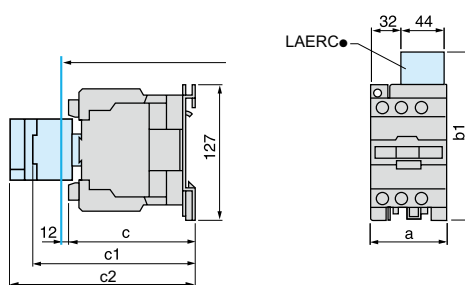

LC1	E80/95
a	85
b1	with LAERC● 135
c	121
c1	with LAEN● 153
c2	with LAETSD 171

### 2 x LC1E06...E65 with LAEM1

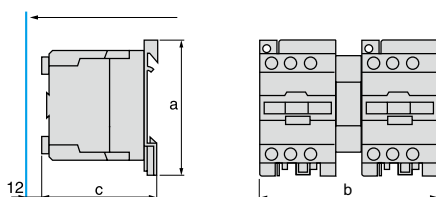

LC1	E06...25	E32...38	E40...65
a	74	84	127
b	104	126	164
c	80	86	114

### 2 x LC1E80/95 with LAEM4

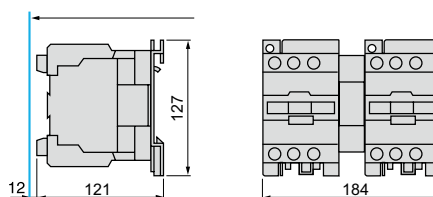

### LC1E120/160

#### On panel with accessories

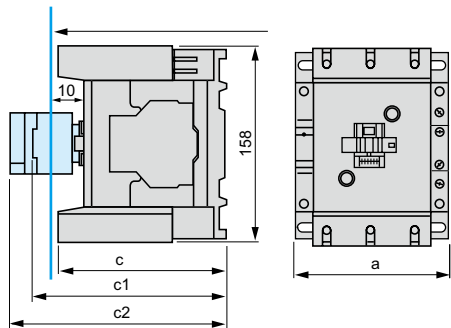

a		120
c	Without add-on blocks	132
c1	With LAEN	150
c2	With LAETSD	168

#### On 2 mounting rails DZ5 MB on 120 mm centres

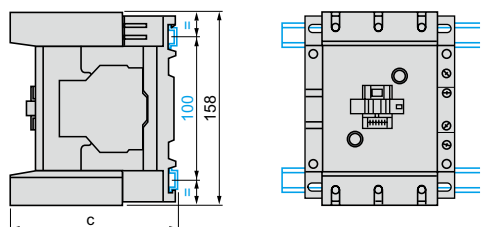

c	(AM1 DP200 or DR200)	134.5
c	(AM1 DE200 or ED●●●)	150

#### On Panel

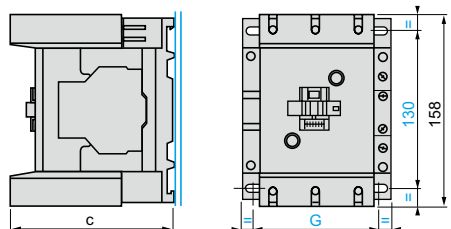

	LC1E120	LC1E160	
c	(AM1 DP200 or DR200)	132	132
G	91/110	96/110	

#### 2 x LC1E120 or LC160 with LAEM5

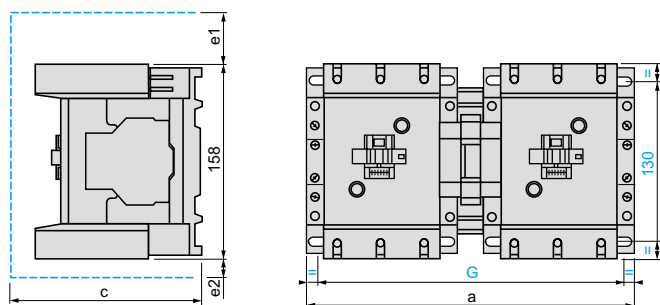

2 x LC1E120 or 160	a	c	e1	e2	G
For 120 and 160	266	148	56	18	242/256

c, e1 and e2: including cabling

### LC1E200 - LC1E250 - LC1E300

On panel

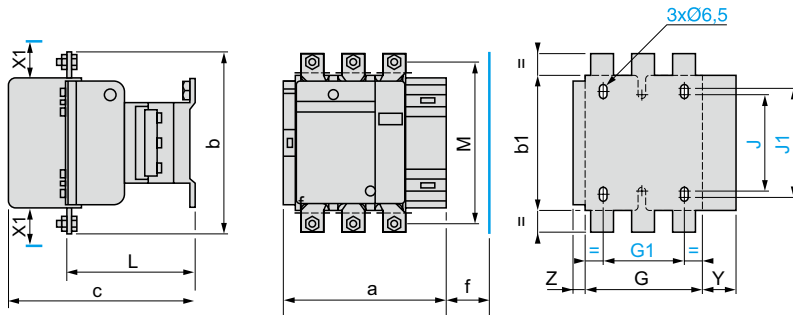

X1 (mm) = minimum electrical clearance according to operating voltage and breaking capacity.

	220...500 V	600...690 V
LC1E200	10	15
LC1E250, 300	10	15

	a	b	b1	c	f	G	G1	J	J1	L	M	P	Q	Q1	S	Y	Z
LC1E200	168.5	174	137	181	130	111	80	106	120	113.5	154	40	29	59.5	20	44	13.5
LC1E250	168.5	197	137	181	130	111	80	106	120	113.5	172	48	21	51.5	25	44	13.5
LC1E300	213	206	145	219	147	154.5	96	106	120	145	181	48	43	74	25	38	20.5

f = minimum distance required for coil removal.

### 2 x LC1E200 or LC1E250 with LAEM6 - 2 x LC1E300 with LAEM7

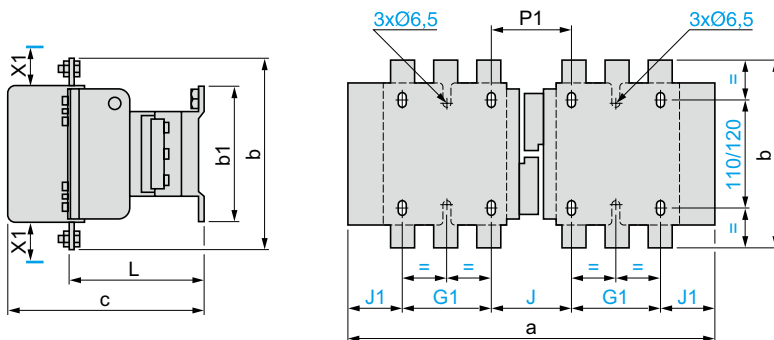

X1 (mm) = minimum electrical clearance according to operating voltage and breaking capacity.

	220...500 V	600...690 V
LC1E200	10	15
LC1E250, 300	10	15

	a	b	b1	c	G1	J	J1	L	P1
2 x LC1E200	357	174	137	181	80	78	59.5	113.5	78
2 x LC1E250	357	197	137	181	80	78	59.5	113.5	62
2 x LC1E300	447	206	145	219	96	124	65.5	145	107

# EasyPact TVS contactors

## LC1E400, E500 and E630 A

### LC1E400 - LC1E500

On panel

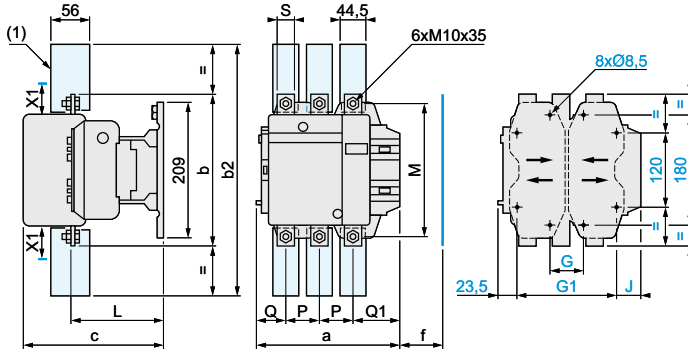

X1 (mm) minimum electrical clearance according to operating voltage and breaking capacity.

	220...500 V	600...690 V
LC1E400	15	20
LC1E500	15	20

(1) Power terminal protection shroud (see page 5/126).

	a	b	b2	c	f	G*	Gmin.	Gmax.	G1*	G1min.	G1max.	J	L	M	P	Q	Q1	S
LC1E400	213	206	375	219	146	80	66	102	170	156	192	19.5	145	181	48	43	74	25
LC1E500	233	238	400	232	150	80	66	120	170	156	210	39.5	146	208	55	46	77	30

f=minimum distance required for coil removal

### LC1E630

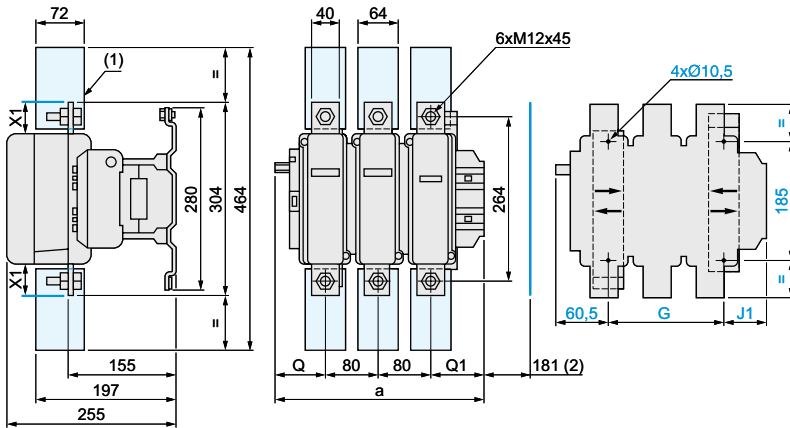

X1 (mm) = minimum electrical clearance according to operation voltage and breaking capacity.

	220...500 V	600...690 V
LC1E630	20	30

(1) Power terminal protection shroud (see page 5/126).  
(2) Minimum distance required for coil removal.

	a	G*	G min	Gmax.	J1	Q	Q1
LC1E630	309	180	100	195	68.5	60	89

### 2 x LC1E400, LC1E500, LC1E630

X1 (mm) = minimum electrical clearance according to operating voltage and breaking capacity.

	220...500 V	600...690 V
LC1E400,500	15	20
LC1E630	20	30

(1) Except LC1 E630 : 4 x Ø 10.5.  
(2) Except LC1 E630.

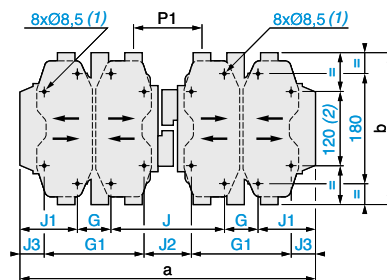

	a	b	b1	c	G	G1	J	J1	J2	J3	L	P1
2 x LC1E400	446	206	209	219	80	170	157	64.5	67	19.5	145	107
3 x LC1E500	485	238	209	232	80	170	156	84.5	66	39.5	146	112
4 x LC1E630	636	304	280	255	180	-	139	68.5	-	-	155	137



# EasyPact TVS contactors

## LC1E06...630 A

### Contactors

#### LC1E06...38

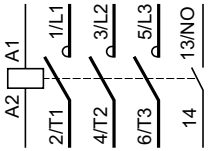

#### LC1E40...95

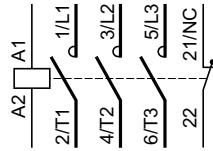

#### LC1E120/160

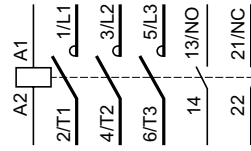

#### LC1E200, 250, 300

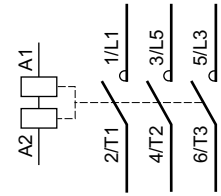

#### LC1E 400,500,630

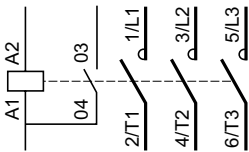

### Reversing contactors

#### 2 x LC1E06...38

#### 2 x LC1E40...95

Horizontally mounted

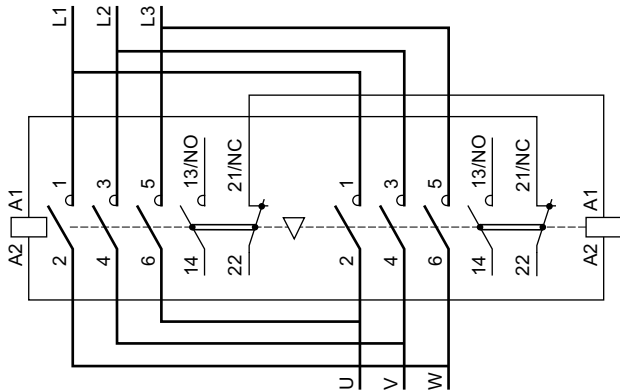
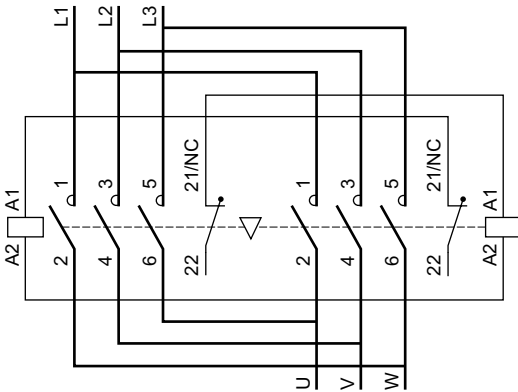

#### 2 x LC1E120, 160

#### 2 x LC1E200, 250, 300

Horizontally mounted

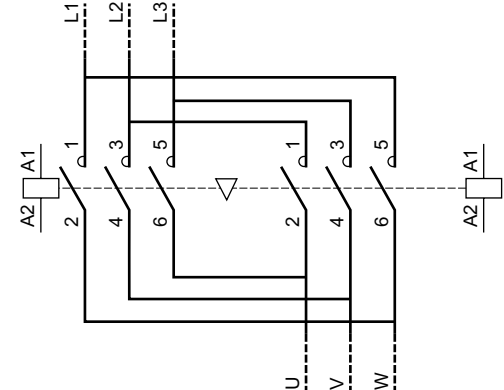
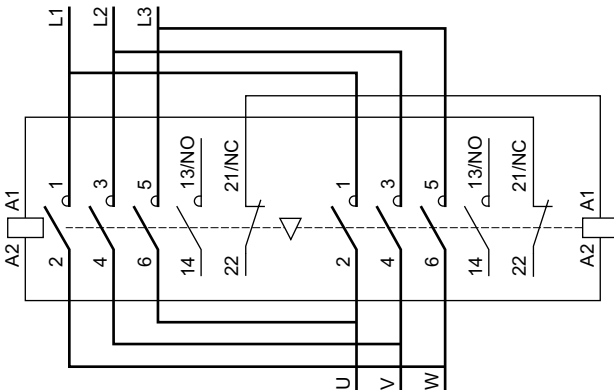

### Front mounting add-on contact blocks

#### 1NO + 1NC (LAEN11) 2NO (LAEN20)

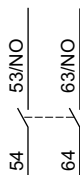
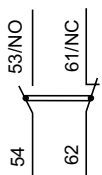

#### 2NC (LAEN02)

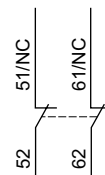

#### 2NO + 2NC (LAEN22)

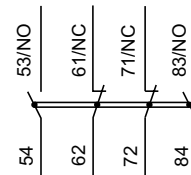

### Time delay auxiliary contacts

On delay 1NO + 1NC (LAETSD)

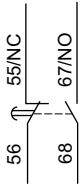

### Mechanical interlock

LAEM●

